

# Research on Three-phase Four-leg Matrix Converter Based More Electric Aircraft Wing Ice Protection System



Your Name \_\_\_\_\_  
 Affiliation \_\_\_\_\_  
 Email Address \_\_\_\_\_

Guo \_\_\_\_\_  
 Affiliation \_\_\_\_\_  
 Email Address \_\_\_\_\_

Paper ID:0002

**Abstract**-In this paper, a new three-phase four-leg matrix converter (TFMC) topology is proposed, and the three-dimensional space vector modulation (3DSVM) strategy is used to realize the output with the three-phase unbalanced load. Aiming at the situation that the icing area of the more electric aircraft (MEA) on the wing is larger than the icing area in the belly, and wing ice protection system (WIPS) is constructed by using the TFMC. Through the real-time detection of the heating element temperature and icing condition by the sensor installed in the wing and belly position, working temperature and three-phase output power of TFMC can be set reasonably. In order to save fuel consumption and reduce operating costs, the key point is to reduce the power transmission in belly position. Finally, simulation and experiment verify the correctness of the proposed 3DSVM strategy and realize the TFMC output with unbalanced three-phase load.

## I. Topology of 3x4 mc

The fourth leg N is added to the neutral point n of the traditional 3X3MC, which constitutes 3X4MC. Topology is shown in Fig.1. 3X4MC model is composed of 12 bidirectional switches, arranged in the form of 3 rows and 4 columns. By controlling the turn-on and turn-off of the bidirectional switch, it can realize the phase connection between any input phase and any one of output four phases, while input cannot short-circuit and output cannot open.

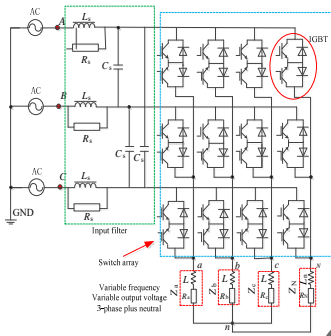

Fig.1 Topology of 3X4MC.

## II. More electric system & WIPS

### A. More electric system

At present, many large aircraft power distribution systems design are different voltage levels of AC and DC power supply. There are two voltage classes of DC voltage, 28V and 270V, in which 28V is used in aircraft avionics. AC voltage includes two forms, 115V and 230V, and 230V is the main distribution network and powered by the starting generators. The design of the MEA distribution system is shown in Fig.2.

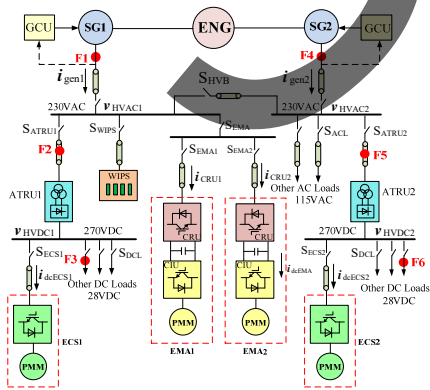

Fig.2 The power distribution system of MEA

Fig.2 shows a design of widely used MEA power distribution system, which composed of two 270VAC main busses, 'HVAC1' and 'HVAC2'. The main engine (ENG) drives two synchronous generators, SG1 and SG2 respectively, utilizing the energy and efficiency supply of the main turbines.

The output voltage of these generators is controlled by the generator control units (GCUs) which are similar to the automatic voltage regulators (AVRs) in power system generator controls. The main units on the AC bus are wing ice protection system (WIPS) and the autotransformer rectifier units (ATRU), which connect two 270V DC buses to supply power to other DC loads. And the DC chopper circuit is used to power the 28V DC avionics equipment. Besides, there is a basic bus that can be fed from any one of the generators. And electro-mechanical actuators (EMA1 and EMA2) driven by a permanent magnetic motor (PMM). The most important load on the DC bus is the environmental control system (ECS) that maintains the temperature and pressure of the civilian aircraft.

### B. WIPS

The anti-icing and de-icing system of the wing based on the TFMC is shown in Fig.3.

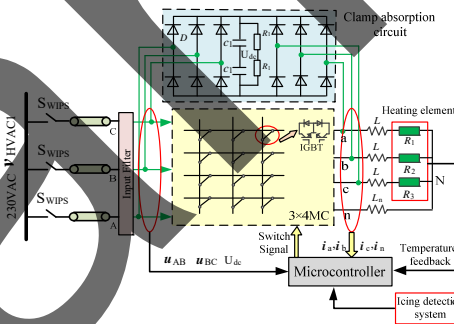

Fig.3 The anti-icing and de-icing system of the wing.

As shown in Fig.3, the topology of the TFMC adopts 12 bidirectional switch IGBT, which is distributed in a matrix. The load adopted the heating element mounted on the leading edge slat and the belly, using star connection. WIPS using a periodic heating method, and stopped when the temperature of the heating element is higher than the preset temperature. The good anti-ice effect is obtained when the heating time is reasonably controlled and energy saving is greatly saved.

### C. Layout of heating elements

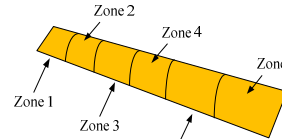

Fig.4 Sketch for MEA thermal mat arrangement

The electric heating de-icing system of aircraft usually uses several heating zones. The study found that heating elements that rely on resistance heating can generate hot spots at the center if the area is large. And the partition heating is not only beneficial to the local temperature control of the de-icing thermal load, but also can effectively avoid the central hot spots

## III. Simulation and experimental results

The simulation model of output with unbalanced load based on TFMC is established by using Matlab/Simulink. And the simulation parameters are as follows:  $U_i=60V$ ,  $m=0.7$ ,  $f_o=50Hz$ ,  $f_s=20kHz$ , load inductance  $L=10mH$ ,  $L_n=10mH$ , load resistance  $R_1=10\Omega$ ,  $R_2=5\Omega$ ,  $R_3=5\Omega$ . The parameters input filter are:  $L_s=1mH$ ,  $C_s=50\mu F$ ,  $R_s=10\Omega$ .

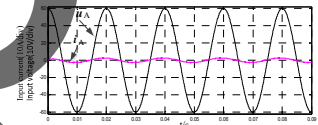

Fig.5 The input current and voltage

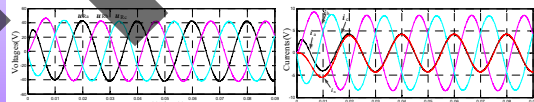

Fig.6 (a) output voltage of three phase loads, (b) output four-leg current.

In Fig.5 and Fig.6, the input voltage and current are sine wave, and the waveform is good, basically the same phase, satisfying the unit power factor. Besides, the voltage and current of the three-phase load are symmetrical, and the current on the fourth bridge arm is about 0A. The simulation results show that the three-phase four-leg matrix converter and the traditional three-phase matrix converter have the same advantages, such as unit power factor input.

## IV. Experimental verification



Fig.7 The 3X4MC platform

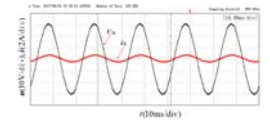

Fig.8 The Input voltage and current

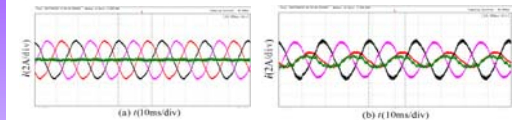

Fig.9 (a) output four-leg current with balance load, (b) output four-leg current with unbalance load

The waveforms of the output currents are sine wave with the phase difference of 120 degrees and the input voltage and current are basically the same phase. The experiment verifies the correctness of the proposed 3DSVM control strategy by separating the positive, negative zero sequence components of the load current.

## V. Conclusions and future work

In this paper, a set of TFMC based on the WIPS to solve the problem of output with unbalanced load, simulation and experimental verify the correctness of the proposed algorithm. The output power of each of the matrix converter is controlled by detecting the heating element temperature and icing condition in the wing and belly. The key is to reduce the power loss at the abdomen position, saving fuel consumption, which has a bright prospect of engineering application.